

832S

S-Band Stub Antenna

3061 Industry Drive, Lancaster, PA 17603-4025 • Tel 717-397-2777 • Fax 717-397-7079 • www.herley.com

FEATURES:

- Developed for airborne application with S-Band transponders
- Vertical polarized omnidirectional enclosed within a radome
- Compact and extremely lightweight while still maintaining the electrical and environmental characteristics
- Simplified mounting



The Model 832S Stub Antenna was developed for airborne application in association with S-Band transponders. The antenna is a vertical polarized omnidirectional antenna enclosed within a radome. The antenna is characterized by its compactness and is extremely lightweight while still maintaining the electrical and environmental characteristics required by this type of antenna.

The skin of the vehicles serves as the ground plane for the antenna due to the simplified mounting technique. Mounting of the antenna is accomplished via a "D" hole through the vehicle skin. It is then secured to the vehicle with a locking nut from inside the vehicle skin.

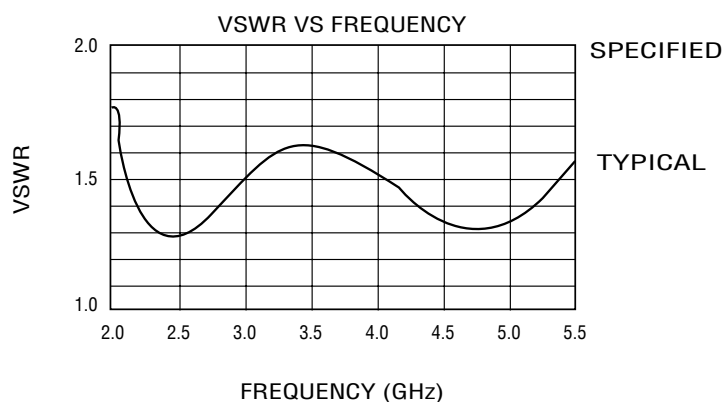
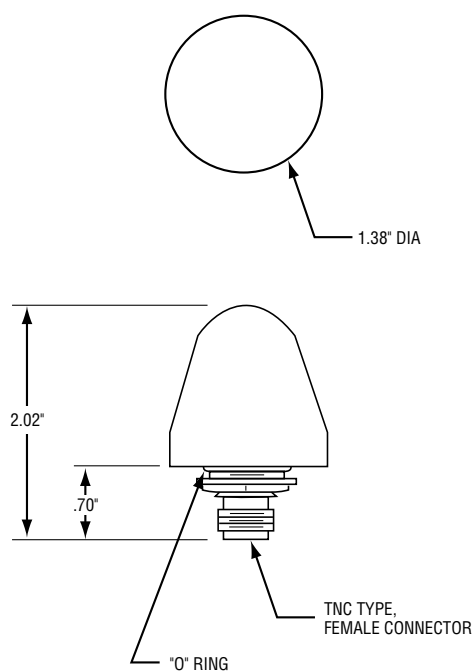

Typical Outline - does not show all features - not to be used for generation of control drawings. For detailed outline drawing of a specific part number please contact Herley Industries, Inc.

EXPORT SALES OF THIS PRODUCT ARE SUBJECT TO U.S. GOVERNMENT APPROVAL.
SALES WILL NOT BE APPROVED TO COUNTRIES PROHIBITED BY THE INTERNATIONAL TRAFFIC IN ARMS REGULATIONS (ITAR).