

# HFTT500-1

## Telemetry Transmitter

3061 Industry Drive, Lancaster, PA 17603-4025 • Tel 717-397-2777 • Fax 717-397-7079 • [www.herley.com](http://www.herley.com)

### FEATURES:

- Linear radiation coverage with minimum aerodynamic drag.
- Antenna body constructed of stainless steel.
- Single or multi-element arrays used.

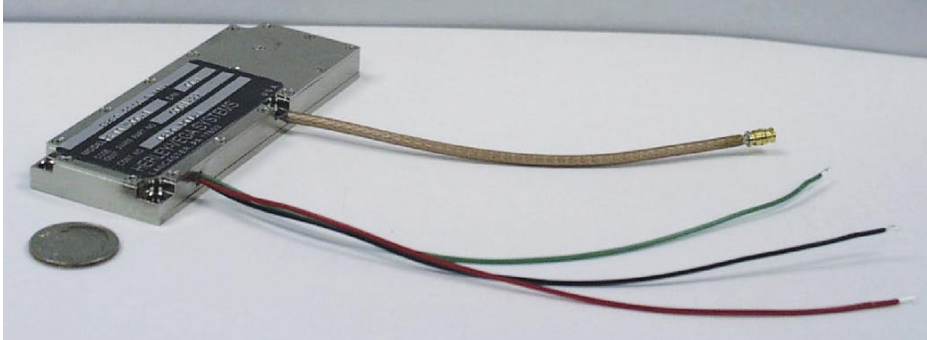

The design of the HFTT500-1 series utilizes the latest in modern devices and circuitry. They are all solid-state to provide a reliable product with extremely long operating life.

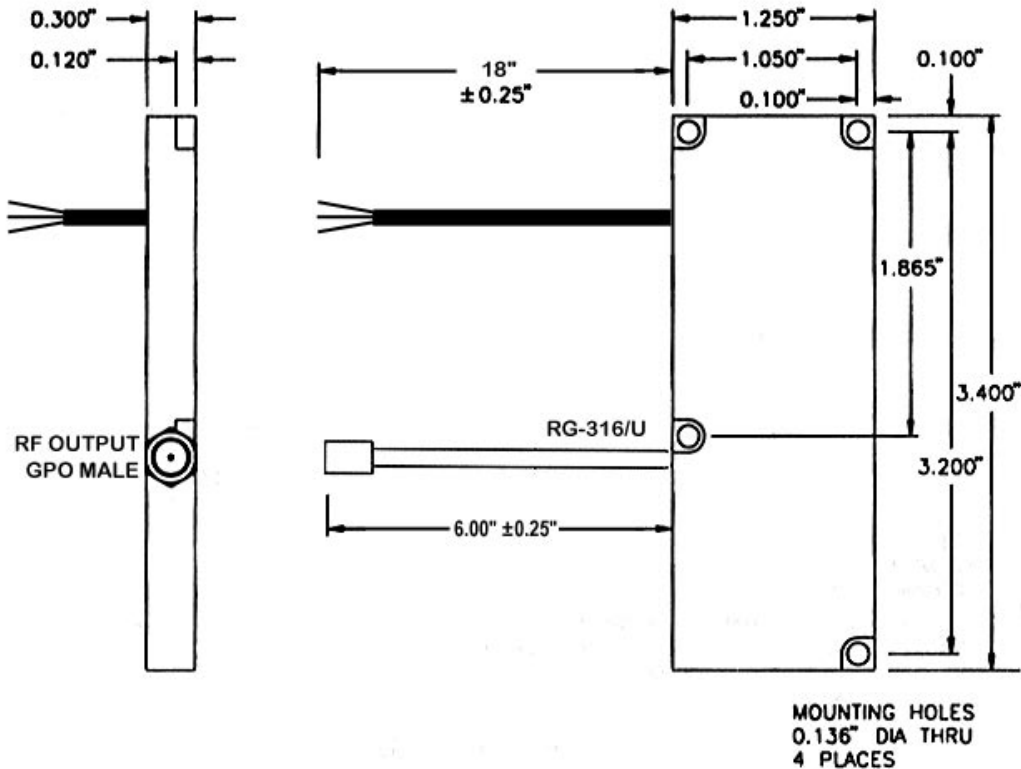

Typical Outline - does not show all features - not to be used for generation of control drawings. For detailed outline drawing of a specific part number please contact Herley Industries, Inc.

EXPORT SALES OF THIS PRODUCT ARE SUBJECT TO U.S. GOVERNMENT APPROVAL.  
SALES WILL NOT BE APPROVED TO COUNTRIES PROHIBITED BY THE INTERNATIONAL TRAFFIC IN ARMS REGULATIONS (ITAR).