

HFFT505TL-1

Telemetry Transmitter

3061 Industry Drive, Lancaster, PA 17603-4025 • Tel 717-397-2777 • Fax 717-397-7079 • www.herley.com

FEATURES:

The HFFT505TL-1 Telemetry Transmitter is a L-band transmitter used primarily to relay telemetry data to a receiving ground station. The units are compact and desirable for those applications where DC power conservation, size and weight are at a premium. Applications include missiles, aircraft, unmanned airborne vehicles (UAV), sounding rockets, drone targets and space launch vehicles.

The design of the HFFT505TL-1 series utilizes the latest in modern devices and circuitry. They are all solid-state to provide a reliable product with extremely long operating life.

- 5 Watt minimum power output
- Lightweight, 12 ounces maximum (340 grams)
- All solid-state design
- Reverse polarity protection

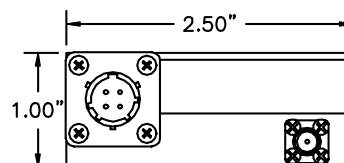
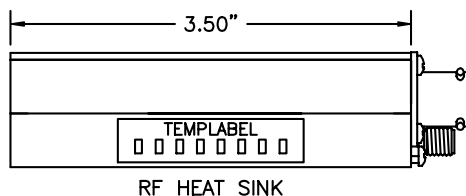
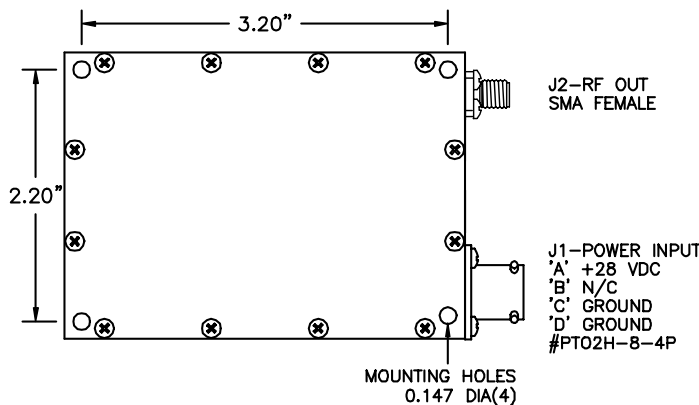
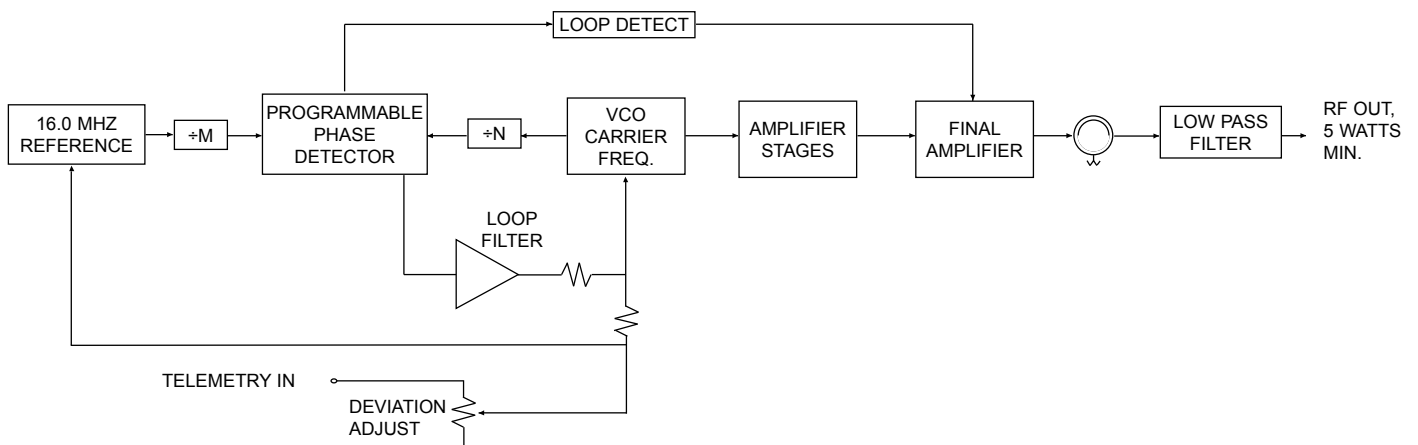

Typical Outline - does not show all features - not to be used for generation of control drawings. For detailed outline drawing of a specific part number please contact Herley Industries, Inc.

EXPORT SALES OF THIS PRODUCT ARE SUBJECT TO U.S. GOVERNMENT APPROVAL.
SALES WILL NOT BE APPROVED TO COUNTRIES PROHIBITED BY THE INTERNATIONAL TRAFFIC IN ARMS REGULATIONS (ITAR).